

QUALIFICATION OF CLEAVAGE FRACTURE TOUGHNESS ON THE BASIS OF LOCAL FRACTURE CRITERION APPROACH

T. MIYATA* , T. TAGAWA* and C. E. CHAVES**

*Department of Materials Science & Engineering, Nagoya University,
464-8603 Nagoya, Japan

** CAE Applications Engineer, Embraer S/A, Av. Brigadeiro Faria Lima,
2170-CEP12227-901, S.J. dos Campos-SP, Brazil

ABSTRACT

Qualification of cleavage fracture toughness is discussed on the basis of the statistical local fracture criterion approach. The Weibull stress criterion is applied to the constraint loss field at the crack tip of the toughness specimen. The constraint effect has been described with the Toughness Scaling Model (TSM) proposed by Anderson and Dodds. New model in which the statistical nature of the cleavage fracture is explicitly taken into account has been proposed. Analytical prediction indicates that the specimen size requirements in toughness to obtain a valid value must be significantly depending on the value of strain hardening exponent and the Weibull shape parameter of the cleavage fracture stress. The 2-dimensional and 3-dimensional FE analysis were performed to confirm above analytical prediction. The 3-dimensional analysis also suggested that the thickness effect on toughness was mainly caused by the statistical volume effect.

The values of the strain hardening exponent, n and the Weibull shape parameter, m for various types of structural steels were experimentally investigated. The results coupled with the analytical prediction demonstrated that the specimen size requirements for a valid toughness shall be prescribed as ' $a, b > 100J_c/\sigma_y$ ' for the most of commercial steels, where a and b are crack size and ligament size of the specimen, respectively.

KEYWORDS

Cleavage fracture toughness, Statistical local fracture criterion, Weibull fracture stress, Constraint effect, Toughness qualification, Size requirement, FEM, Steels

INTRODUCTION

Loss of constraint due to a shallow notch or large scale yielding decreases the stress level at the crack tip and causes high toughness [1,2]. Dodds and Anderson [3] quantified the deviation in stress distribution caused by the loss of constraint and developed the toughness scaling model (TSM). Based on their works size requirements to achieve sufficient constraint that is equivalent with the small scale yielding condition is proposed approximately as in the ASTM E-1820-96:

$$B, b_0 > MJ_c / \sigma_y, M = 200 \quad (1)$$

where B is the specimen thickness, b_0 is the ligament length of the specimen, J_c is the critical J-integral, and σ_y is the effective yield strength of the material. The value of M , the constraint factor, was soon revised to be 50 according to 3-dimensional FE analysis [4]. Recently, the ASTM E-1820 (1999) was also revised to that M should be 100 except for given particular materials of $M=50$. The Weibull stress criterion [5,6] is applied to the toughness scaling model, and the effect of constraint loss is described as a function of the stress contour similarity ratio and the Weibull shape parameter, m of the cleavage fracture stress [7]. Analytical model predicts that the effect of constraint on the toughness strongly depends on the Weibull shape parameter of the material. The materials that have higher value of m , that implies small scatter in the cleavage fracture stress, are able to obtain a valid toughness in smaller specimens. In the present work, two- and three-dimensional FE analysis coupled with the Weibull stress criterion were performed to confirm the above theoretical prediction. Then, the value of the Weibull shape parameter in the commercial steels were investigated and the validity of the ASTM prescription on the size requirements has been discussed.

WEIBULL STRESS SCALING MODEL

Anderson and Dodds [1] quantified stress contour similarity at the crack tip between the large scale yielding (LSY) condition and the small scale yielding (SSY) condition. They successfully expressed the LSY stress field in terms of the constraint loss factor, ϕ and the SSY stress field. The variable, ϕ is defined as the similarity ratio in the area of a specified stress contour at the crack tip. The apparent J-integral for the LSY condition, J_{LSY} is converted to the J_{SSY} as,

$$J_{cSSY} = J_{cLSY} \phi^{1/2} \quad (2)$$

The Weibull stress σ_w is defined as [5],

$$\sigma_w = \left[\int_{V(\sigma_1 > \sigma_{th})} \sigma_1^m \frac{dV}{V_0} \right]^{1/m} \quad (3)$$

where V is the volume subjected to the maximum principal stress σ_1 , and V_0 is a unit volume of the material. The exponent m is the Weibull shape parameter for the critical Weibull stress at cleavage fracture. When a stress singularity can be assumed as a level of exponent β , the principal stress, σ_1 ahead of the crack tip can be described as

$$(\sigma_1 / \sigma_0)_{SSY} = g(\theta) (J_{SSY} / r \sigma_0)^\beta \quad (4)$$

The HRR stress field corresponds to $\beta = 1/(n+1)$, where n = the strain hardening exponent, and $g(\theta)$ is a geometrical function of the specimen. The stress field for the LSY can be written in analogy to the SSY as

$$(\sigma_1 / \sigma_0)_{\text{LSY}} = g(\theta) (\phi^{1/2} J_{\text{LSY}} / r \sigma_0)^\beta \quad (5)$$

Substituting Eq.(5) to Eq.(3), the following relation can be derived [7],

$$J_{c\text{SSY}} = J_{c\text{LSY}} \phi^{1/\beta m} \quad (6)$$

This formulation indicates that the TSM is the one particular case of the Weibull stress criterion dependent on the combinations of n and m . The values of ϕ are numerically given as a function of n by Anderson and Dodds [3] and the fitting equation of ϕ for a bend specimen with notch depth, $a/W=0.5$, as follows:

$$\frac{J_{\text{LSY}}}{J_{\text{SSY}}} = \frac{1}{\phi^{1/2}} = 1 + \Phi \left(\frac{J_{\text{LSY}}}{b_0 \sigma_0} \right)^\gamma \quad (7)$$

$$\Phi = 0.8425 n^{2.262}$$

$$\gamma = 1.126 + 0.01925 n - 8.333 \times 10^{-5} n^2$$

Assuming that the SSY stress field can be described with the HRR solution, the exponent β is replaced with $1/(n+1)$. From Eq.(6) and Eq.(7), the ratio of J_{LSY} to J_{SSY} can be evaluated as:

$$\frac{J_{\text{LSY}}}{J_{\text{SSY}}} = \left(\frac{1}{\phi^{1/2}} \right)^{\frac{2n+2}{m}} = \left\{ 1 + \Phi \left(\frac{J_{\text{LSY}}}{b_0 \sigma_0} \right)^\gamma \right\}^{\frac{2n+2}{m}} \quad (8)$$

Figure 1 shows the results of Eq.(8), denoted as the WSSM, in comparison with the TSM. The specimen size requirement parameter, $M (=b_0 \sigma_0 / J_{\text{LSY}})$ is solved for $J_{\text{LSY}} / J_{\text{SSY}} = 1.2$ as a function of n . The value of M indicates the limiting value to obtain the toughness within a deviation less than 20% from the SSY condition, and corresponds to the constraint factor, M in Eq.(1). Those results suggest that the SSY toughness of the materials with large value of m and smaller value of n can be obtained in smaller specimens.

2-D AND 3-D FEM ANALYSIS

In order to confirm above analytical prediction and to clarify the three dimensional size effect, 2- and 3-dimensional FE analysis were performed using the WARP 3D [8]. Finite element models for toughness specimens are shown in Fig.2. 2D-SSY analysis was performed using the semi-circular model with the boundary of the SSY singularity [4]. The Ramberg-Osgood type constitutive equation with yield strength, $\sigma_0 = E/500$, was adopted. The value of J -integral was calculated from both the path integral ($J_{\text{d.i.}}$) and the load-displacement

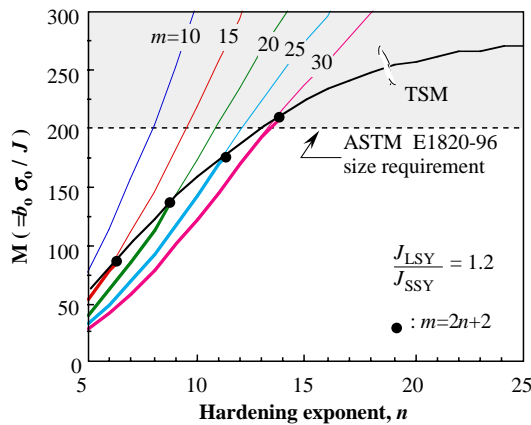

Fig.1 Comparison of WSSM with TSM on specimen size requirements.

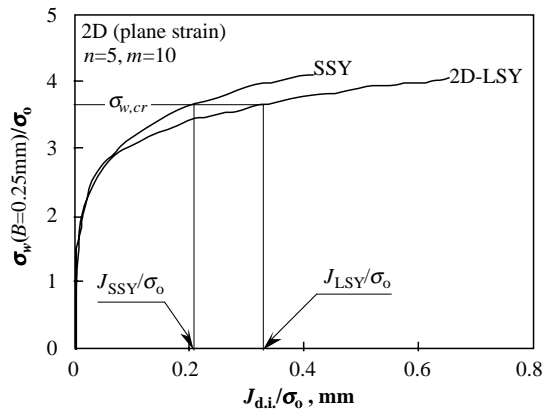

Fig.3 Relation between the Weibull stress, σ_w and J integral.

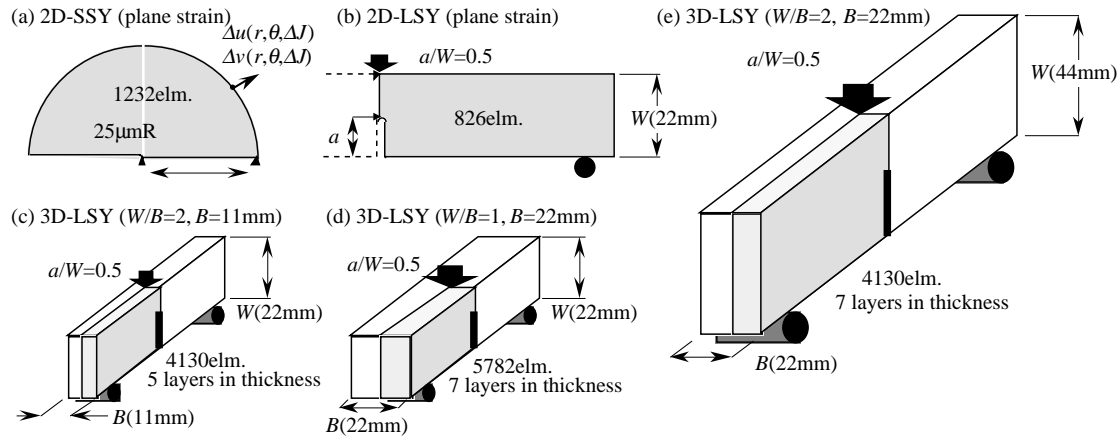

Fig.2 Finite element models for fracture toughness specimens.

curve ($J_{p,\delta}$). In the case of the 2-D plane strain analysis, both J integral values are consistent with others. The Weibull stress was calculated in the zone of $\sigma_1 > \sigma_{th} = 2\sigma_0$ and $\sigma_{th} = 3\sigma_0$.

Figure 3 shows an example of results on relation between the Weibull stress, σ_w and J -integral (J_{di}). The ratio of J_{LSY} to J_{SSY} can be estimated with an assumption of the Weibull stress criterion according to the procedure shown in the figure. When the value of $\beta m = 2$, the TSM model must coincide with the present WSSM model with the assumption of the HRR singularity. Figure 4 shows a comparison of the both model for the case of

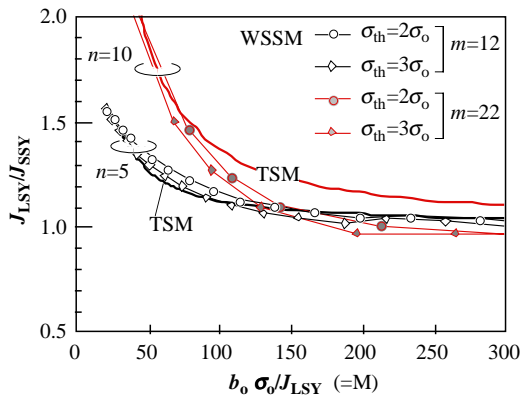

Fig.4 Comparison between TSM and WSSM in the case of $\beta m = 2$.

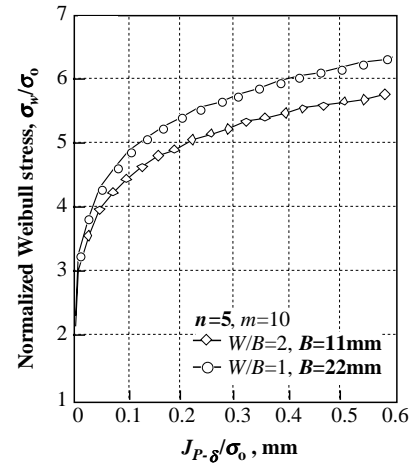

Fig.5 Relations between the Weibull stress, σ_w , and J integral for 3D models with the same in-plane specimen size.

$\beta m = 2$ in terms of relations between J_{LSY}/J_{SSY} and $b_0\sigma_0/J_{LSY}$. Bold lines indicate the results of Anderson and Dodds[1] and fine lines are the plane strain FEM results of the WSSM model. The results shown in Fig.4 support numerically the validity of the WSSM model.

The value of J integral in the 3-D FE analysis is varied with its definition. Path integral value in a given plane distributes along with the crack front in direction of the thickness. Average value through the thickness is different from $J_{p,\delta}$ especially in the large scale yielding. In the present work, $J_{p,\delta}$ is adopted for the discussion because $J_{p,\delta}$ is more significant in practical toughness testing. The estimated values of the Weibull stress of the specimens with different thickness but the same in-plane size are shown in Fig.5. Thicker specimen has larger value of the Weibull stress involving both the constraint effect and the statistical volume effect. Figure 6 shows an example on the ratio of J_{LSY} to J_{SSY} as a function of J_{LSY} . Bold line indicates the results on the plane strain 2-D FE analysis. The value of J_{SSY} in the 2-D analysis is modified to the equivalent value with the same thickness of the 3-D specimens. It implies that the effect of volume is eliminated in the value of the ratio. Although in the case of $m=10$, the constraint effect can be observed, the ratio of J_{LSY} to J_{SSY} is almost the same in the specimens of $B=11\text{mm}$ and 22mm in the case of $m=20$ and 30 . This result implies that the constraint effect due to the

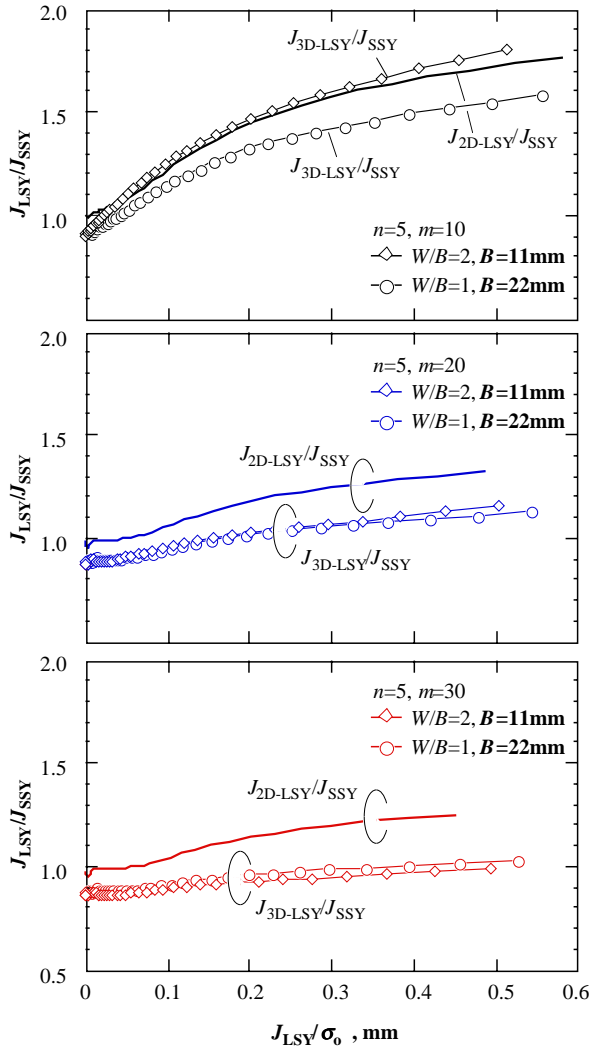

Fig.6 Comparison of constraint loss effect in the specimens of $B=11\text{mm}$ and $B=22\text{mm}$.

increase of the thickness is relatively small in the materials that have larger value of the Weibull shape parameter, m .

EXPERIMENTAL ANALYSIS ON THE WEIBULL SHAPE PARAMETER, m

Theoretical and numerical analysis suggest the significant role of the Weibull shape parameter, m in qualification of the cleavage fracture toughness. For several materials the value of m was investigated experimentally using notched round bar specimens. However, the data is insufficient to discuss general tendency in practical steels. The Beremin's model gives a description of the cleavage fracture toughness as [5]:

$$J_c = \frac{\text{Const.}}{B^{1/2}} \sigma_0^2 \left(\frac{\sigma_{w,cr}}{\sigma_0} \right)^{m/2} \quad (9)$$

The Weibull fracture stress and its shape parameter, m are assumed to be constant irrespective of the temperature. Equation (9) indicates that temperature dependence of the fracture toughness is mainly caused by the variation of the yield strength of the materials. From the experimental data on the toughness of various type of steels [9], the value of m was evaluated according to Eq. (9) and iteration procedure shown in Fig. 7. The evaluated values of m are shown in Fig. 8 as a function of the yield strength at room temperature together with the experimental values of m obtained in notched round bar specimens. The values of m vary in the range of 10

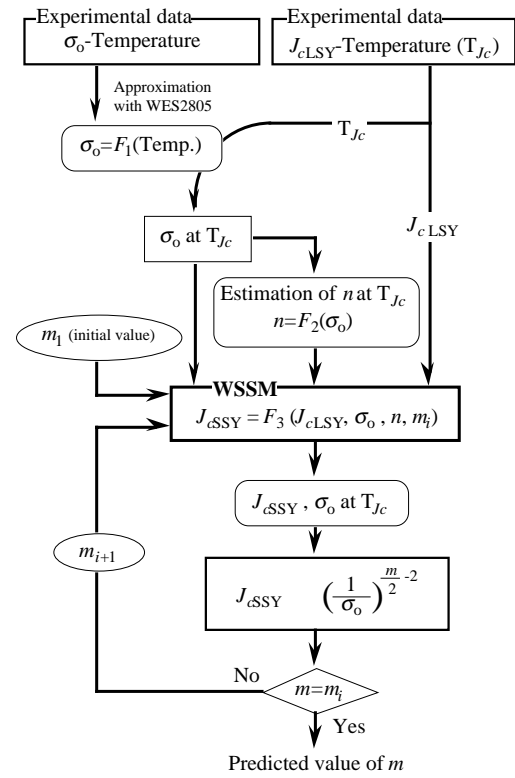

Fig.7 Predicting flow for m from toughness transition data.

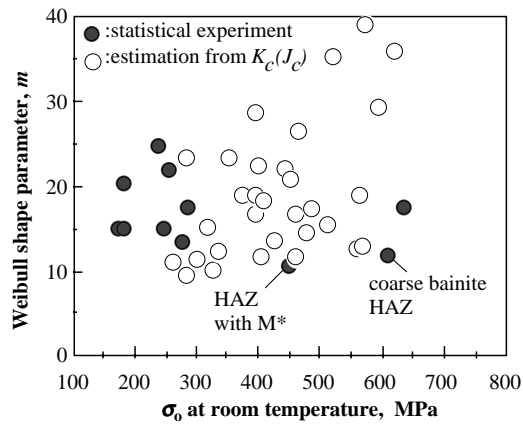

Fig.8 m values for low carbon steels.

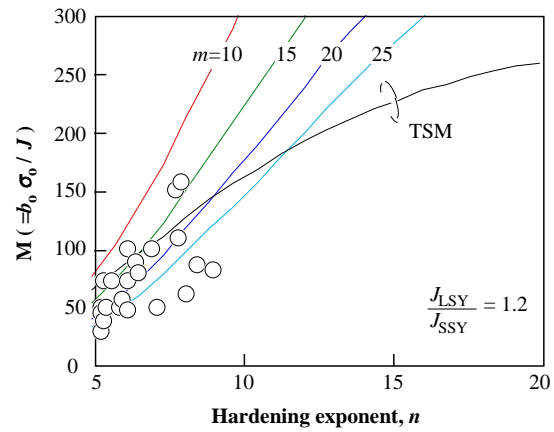

Fig.9 Constraint factor, M for commercial steels.

to 40. The lower toughness material generally has a lower value of m . The values of the strain hardening exponent, n were simultaneously investigated. Based on these values of m and n , corresponding constraint factor, M that gives the ratio of J_{LSY} to J_{SSY} of 1.2 can be obtained from Eq. (8) as is shown in Fig.9. The results shown in Fig.9 indicate that the constraint factor, M in Eq. (1) for the most of the practical steels are in the range of 50 to 100 except for low toughness materials and the revision of the ASTM E1820 in 1999 is reasonable.

CONCLUSIONS

The Weibull stress criterion was applied to the toughness scaling model proposed by Anderson and Dodds [1]. The proposed new model suggests that the size requirements for specimen to obtain the sufficient constraint in toughness testing are strongly depending on the value of the Weibull shape parameter, m and the strain hardening exponent, n of the materials. This analytical prediction was confirmed by the FE analysis coupled with the Weibull stress criterion. Three dimensional FE analysis simultaneously indicates that the thickness effect in toughness is mainly caused by the statistical volume effect especially for the materials with the high value of m . The values of the shape parameter, m were estimated from the transition curve of the cleavage fracture toughness. The constraint factor, M to obtain the J_{SSY} is presumed as in the range of 50 to 100 for the most of commercial steels and it is consistent with the revision in the ASTM E 1820.

REFERENCES

- [1] Anderson, T. L. and R. H. Jr. Dodds, (1991) J. Testing and Evaluation, 19, 123-134.
- [2] O'Dowd, N. P. and C. F. Shih, (1992) J. Mechanics and Physics of Solids, 39, 898-1015.
- [3] Dodds, R. H. Jr., T. L. Anderson and M. T. Kirk, (1991) Int. J. Fracture, 48, 1-22.
- [4] Nevalainen, M. and R. H. Jr. Dodds, (1995) Int. J. Fracture, 74, 131-161.
- [5] Beremin, F.M., (1983) Metallurgical Trans. A14, 2277.
- [6] Mudry, F., (1986) Nuclear Eng. and Design 105, 65.
- [7] Miyata, T., T. Tagawa and Y. Hongkai, (2000) J. Testing and Evaluation, 28, 62-65.
- [8] Koppenhoefer, K., A. Gullerud, C. Ruggieri, R. H. Jr. Dodds and B. Healy, (1997) WARP 3D 9.8 Dynamic Nonlinear Analysis of Solids Using a Preconjugate Gradient Software Architecture, Structural Research Series 907, University of Illinois at Urbana-Champaign.
- [9] Miyata, T., Tagawa, T. and Aihara, S., (1995) Tetsu to Hagane(J. the Iron and Steel Institute of Japan) 81, 583.